



SUPASTOR UNVENTED CYLINDERS

Installation, commissioning and maintenance instructions

Direct and indirect enamelled cylinders:
120, 150, 180, 210, 250 and 300 litres



BS EN ISO 9001
Certificate No: FM 34109

Flamco UK Limited.
Unit 4,
St. Michael's Road,
Lea Green Industrial Estate,
St. Helens
Merseyside WA9 4WZ.
Telephone: 01744 818100.
Fax: 01744 830400.
Email: info@flamco.co.uk
www.flamco.co.uk

Important:
Please read these instructions carefully before proceeding
with installation. Failure to do so may invalidate warranty.

SUPASTOR UNVENTED CYLINDERS

Installation, commissioning and maintenance instructions

WATER BYE-LAWS

Only approved materials, pipes and fittings that comply with water bye-laws should be used.

BUILDING REGULATIONS

The installation of an unvented hot water storage cylinder is regulated by Building Regulations G3. To meet the requirements of the Regulation, installation of an unvented system should be undertaken by a 'competent installer'.

IMPORTANT

It is important to note that it is a criminal offence to install an unvented hot water storage system without notifying your Local Authority.

SUPASTOR DIRECT CYLINDER (Diagram A)

The Supastor direct cylinder, available in nominal capacities of 120 litres, 150 litres, 180 litres, 210 litres, 250 litres and 300 litres, are supplied as:-

One large box containing -

The Supastor unit with factory fitted temperature and pressure relief valve and magnesium anode.

One small box containing -

The unvented kit which consists of a 12 litre expansion vessel, pressure reducing valve set at 3 bar with in-line strainer, a safety group (expansion relief valve, tundish and single check valve) and two immersion heaters.

SUPASTOR INDIRECT CYLINDER (Diagram B)

The Supastor indirect cylinder, available in nominal capacities of 120 litres, 150 litres, 180 litres, 210 litres, 250 litres and 300 litres, are supplied as:-

One large box containing -

The Supastor unit with factory fitted temperature and pressure relief valve, cylinder thermostat and magnesium anode.

One small box containing -

The unvented kit which consists of a 12 litre expansion vessel, pressure reducing valve set at 3 bar with in-line strainer, a safety group (expansion relief valve, tundish and single check valve), a 2-port motorised valve and one immersion heater.

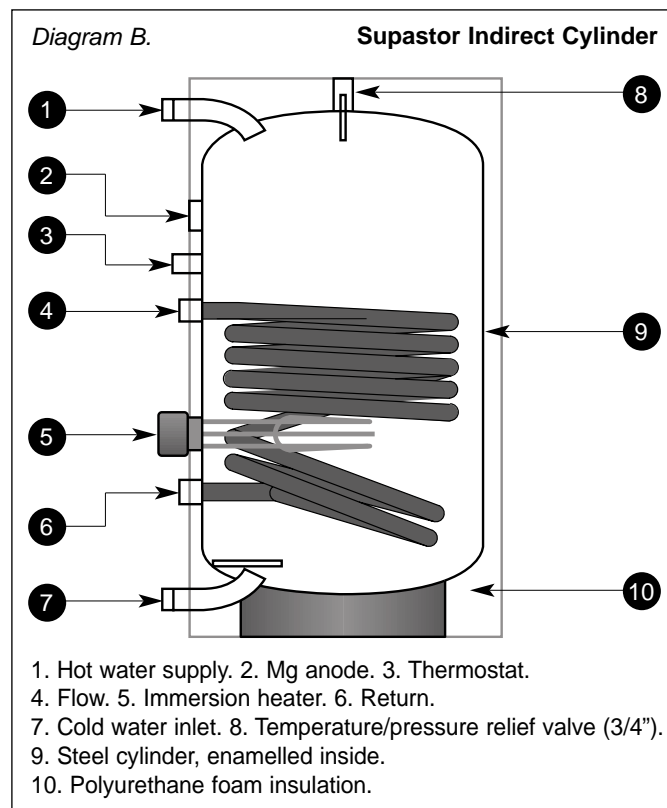
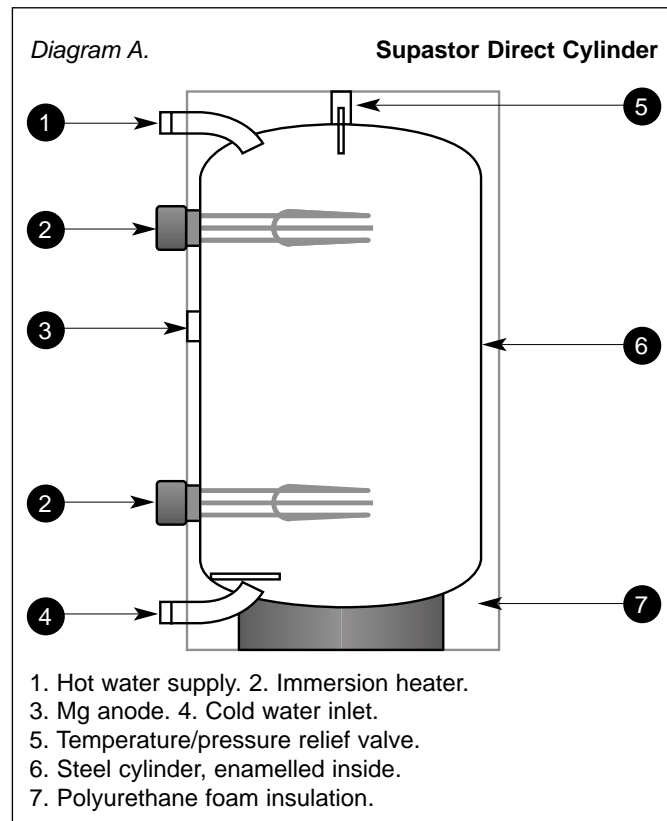

Schematic diagram of Supastor direct unvented hot water controls.

Diagram I.

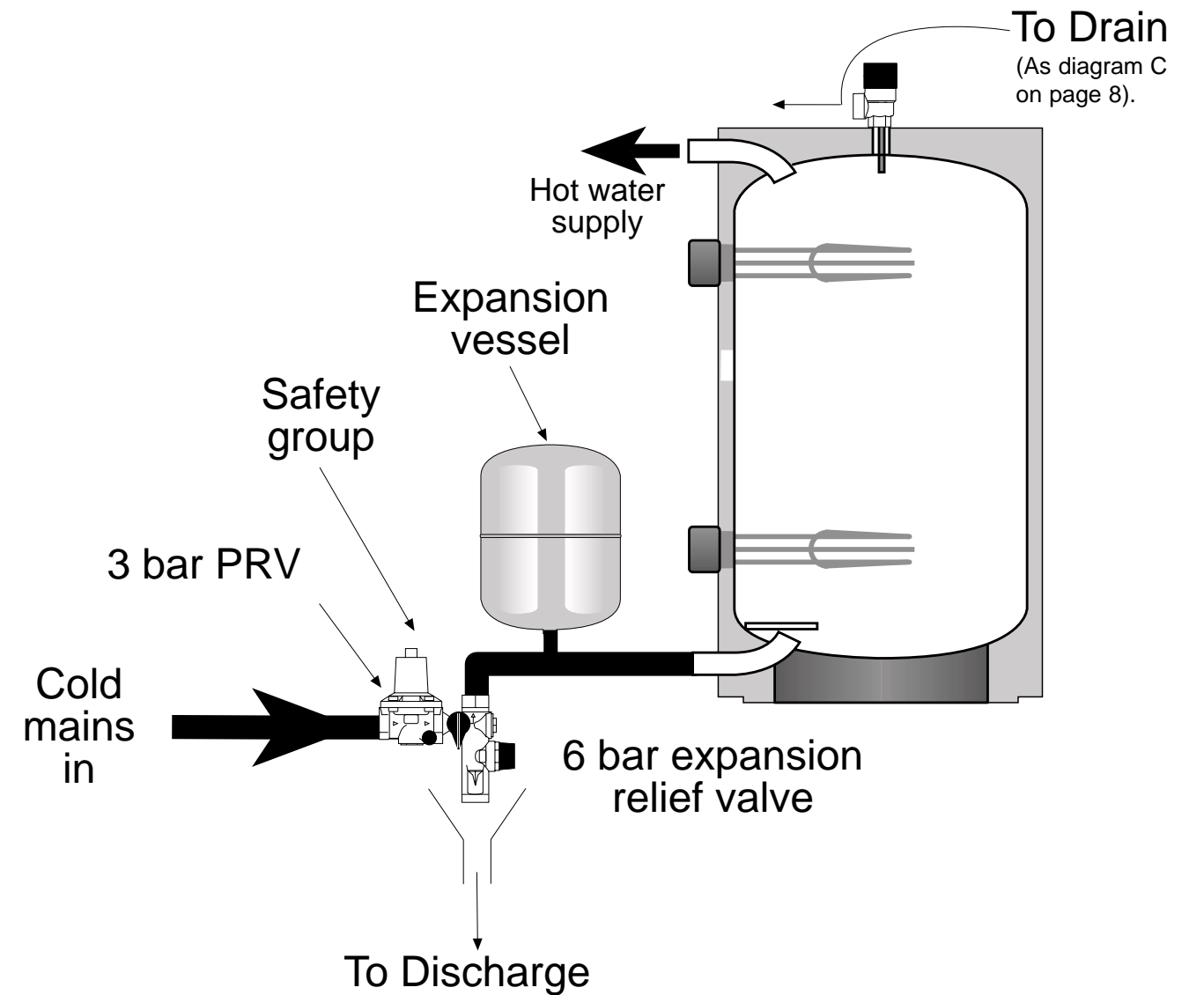

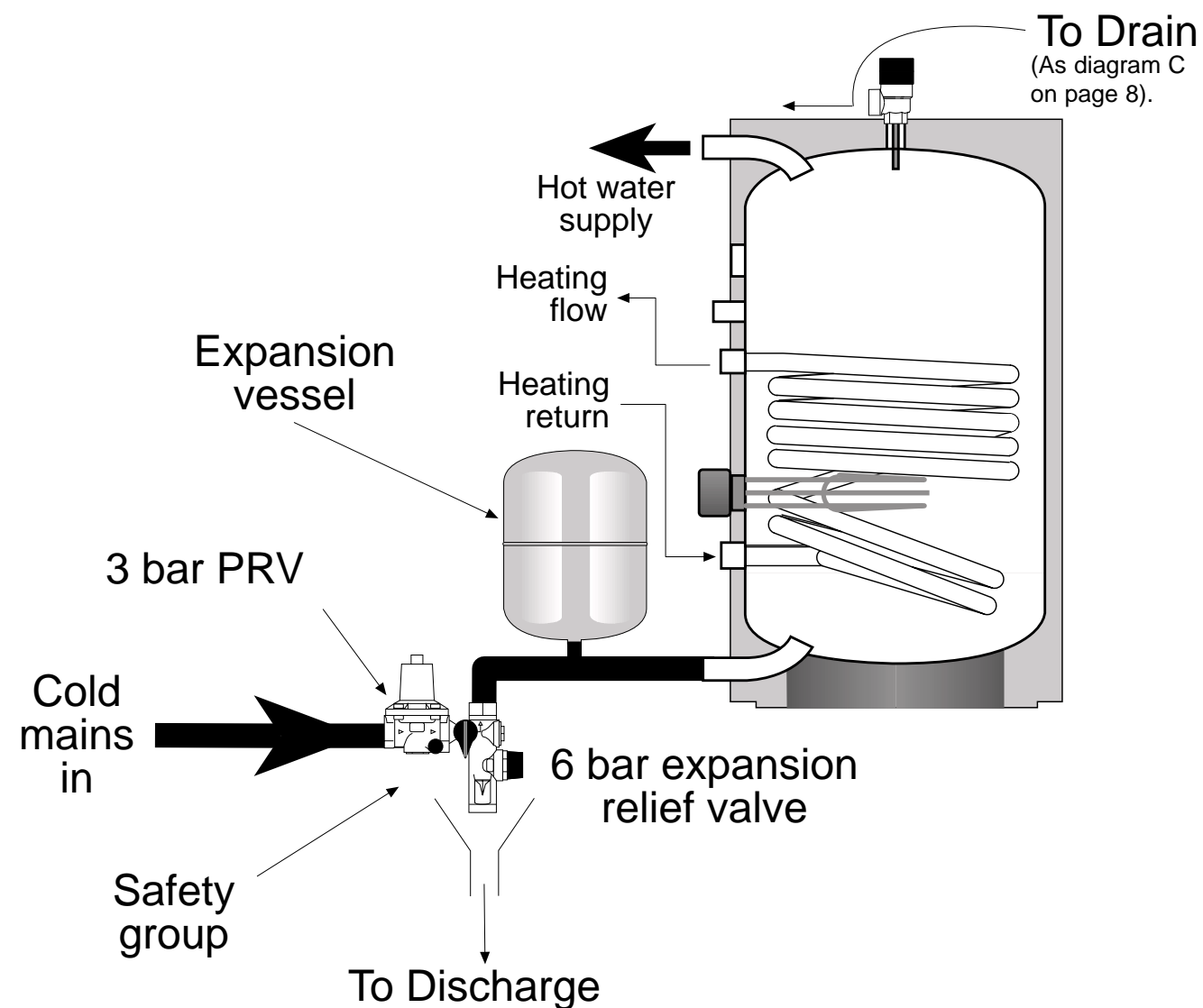
**NOTE:**

All components must be fitted.

If the system is to be fitted with a 3 port valve, the 2 port valve supplied by Flamco must still be fitted.

THE CYLINDER

The cylinder must only be installed in the vertical position. The inlet pipe delivers cold water to the bottom of the cylinder. An unvented kit is provided which comprises of a Flexcon expansion vessel (to accommodate any increase in water volume), pressure reducing valve and safety group (expansion relief valve, tundish and single check valve. **IMPORTANT** - the discharge from the expansion relief valve must be made and piped away safely.

COLD WATER SUPPLY

The mains water pressure must not exceed 12 bar.

As hot and cold water are both drawn off the same supply, it is important to ensure that the cold water feed is capable of supplying the **full** demand. Please identify all the connection ports before making any connections to the cylinder (See diagrams A and B on page 2).

For maintenance, position an isolating valve between the cold water supply and the cylinder.

All pipework must be flushed clean to avoid any damage to the controls.

INDIRECT CYLINDERS

Indirect cylinders are supplied with a 2-port motorised valve in accordance with Water Board regulations G17.1(b), and have dual thermostatic controls.

A separate cylinder thermostat is supplied to control the indirect circuit via the motorised valve. In accordance with Water Bye-Law G20.6, and integral thermal cut-out stat is incorporated within the cylinder stat housing, and is wired through to the heat source, and operates if the water temperature rises too high. Should the thermal cut-out activate it can only be re-set manually. **Under no circumstances should this be by-passed. The activation indicates a fault which must be rectified by a qualified engineer.** Refer to diagram E on page 8 for recommended wiring details.

IMMERSION HEATERS

The cylinder immersion heater(s) are connected through a thermostat which pre-sets the operating temperature. The required operating temperature can be adjusted at the head of the thermostat. In accordance with Water Bye-Law G20.6 the immersion heater is pre-wired through a thermal cut-out stat, which operates if the water temperature rises too high. Should the thermal cut-out activate it can only be re-set manually. **Under no circumstance should this be by-passed. The activation indicates a fault which must be rectified by a qualified engineer.** Refer to diagram G on page 9.

FITTING THE IMMERSION HEATER(S)

The electrical installation must be in accordance with the current I.E.E. wiring regulations. Care must be taken not to cross thread the immersion heater(s) when fitting.

A 220/240V mains supply fused 13 amp is required. Heat resistant cable, round 3 or 4 core 2.5mm² (to BS.6141. table 8) must be used to connect the electrical supply through the Economy 7 time control switch as shown in diagram G on page 9.

If the Economy 7 system is not used then a separate 13 amp supply to each element will be required through a double pole fused isolating switch having a contact gap of at least 3mm on each pole. Make the connection(s) to the immersion heater(s).

The thermostat(s) on the immersion heater(s) should be adjusted to trip at 60°C. This is the ideal temperature to prolong the element's life in hard water areas. Scale on the sheath builds up more rapidly at temperature above 60°C causing the element to overheat and premature failure could occur. Higher temperatures without additional controls would result in scalding.

WARNING: THE APPLIANCE MUST BE EARTHED

The earth continuity conductor of the electrical installation must be effectively connected to all exposed parts of other appliances and services in the room where the unvented cylinder is housed - conformity with the I.E.E. regulations.

SITING THE UNVENTED CYLINDER

As the unvented cylinder is connected directly to the mains cold water supply, the siting is optional. However, for easy maintenance leave free space for access to the electrical components (immersion heater(s) and anodes). Care should be taken to ensure the support of the load bearing strength as per the table below.

Supastor Size	120 litre	150 litre	180 litre	210 litre	250 litre	300 litre
Weight full Direct unit	173 kg	192 kg	223 kg	255 kg	305 kg	356 kg
Weight full Indirect unit	181 kg	203 kg	234 kg	272 kg	322 kg	376 kg

TEMPERATURE AND PRESSURE RELIEF VALVE

The factory fitted temperature and pressure relief valve, sited on top of the unvented cylinder, is a safety device to back-up and support the thermostat(s) and thermal cut-out(s). It operates when either excess pressure or excess temperature is sensed. When operated, hot water will be discharged so care must always be taken. The discharge is connected to a tundish and drain.

Note: The temperature and pressure relief valve must not be removed under any circumstance. Such action will invalidate the warranty.

DISCHARGE PIPEWORK FROM THE TEMPERATURE AND PRESSURE RELIEF VALVE

The tundish must be vertical and fitted within 300mm of the temperature and pressure relief valve and must be located near the unvented cylinder. The tundish must also be in a position visible to the occupants, and positioned away from electrical devices. The discharge pipe from the tundish should be metal and should terminate in a safe place where there is no risk to persons in the vicinity of the discharge.

Refer to diagram C on page 8.

ALL INSTALLATIONS MUST CONFORM TO BUILDING REGULATIONS G3.

COMMISSIONING

Check for obvious signs of damage to the unvented cylinder and associated controls.

Do not switch the immersion heater(s) or fire the boiler until the unvented cylinder is full of water.

1. Open all outlet taps.
2. Turn on mains water supply and allow the unvented cylinder to fill.
3. Close taps in turn after having purged the system of air.
4. Check for leaks around the controls and immersion heater(s). Repeat this check again after the unit has heated up.
5. Check that no water is passing to discharge through the temperature and pressure relief valve and the expansion relief valve.
6. Test the operation of the temperature and pressure relief valve and the expansion relief valve by lifting/turning the manually operated test cap and ensure that water flows through freely and safely to waste.
7. Check that the discharge pipe is plumbed so that it falls continuously and that no taps, valves or other shut-off devices are installed in the pipe.
8. Check that all thermostats are set to 60°C.
9. DIRECT UNITS: Switch on immersion heater(s) and allow the unit to heat up. Check the operation of the thermostat(s).
10. INDIRECT UNITS: Fill the indirect (primary) circuit, following the boiler instructions. Switch on the boiler, ensuring that the programmer is set to domestic hot water. Allow the unit to heat up and check the operation of the cylinder thermostat on the motorised valve.
11. Demonstrate the operation of the unit to the occupier, including the temperature and pressure relief valve and what to do if it operates.
12. Give this manual to the occupier to retain for future reference and make the occupier aware that periodic checks of the equipment are essential for safety.
13. Complete the 'Supastor Service History Book' provided and leave with the occupier.

MAINTENANCE OF THE MAGNESIUM ANODE

The installer should check the magnesium anti-corrosion anode after two years (consult the label on the face of the unit for correct location). If the heating element is heavily coated with scale we recommend descaling at the time of this inspection. If the anode is still operational and is not replaced then further annual checks are required. If the anode is replaced then it does not need re-checking for a further two years.

EXAMINE THE ANODE AND REPLACE IF THE DIAMETER IS LESS THAN 15mm.

Removal of Anode:

1. Close the mains supply service valve.
2. Open hot water taps.
3. Ensure the cylinder is empty.
4. The anode can now be removed.
5. Descale the immersion heater(s) and remove any lime deposit from the cylinder and heating element.

Replace in reverse order.

(continued overleaf)

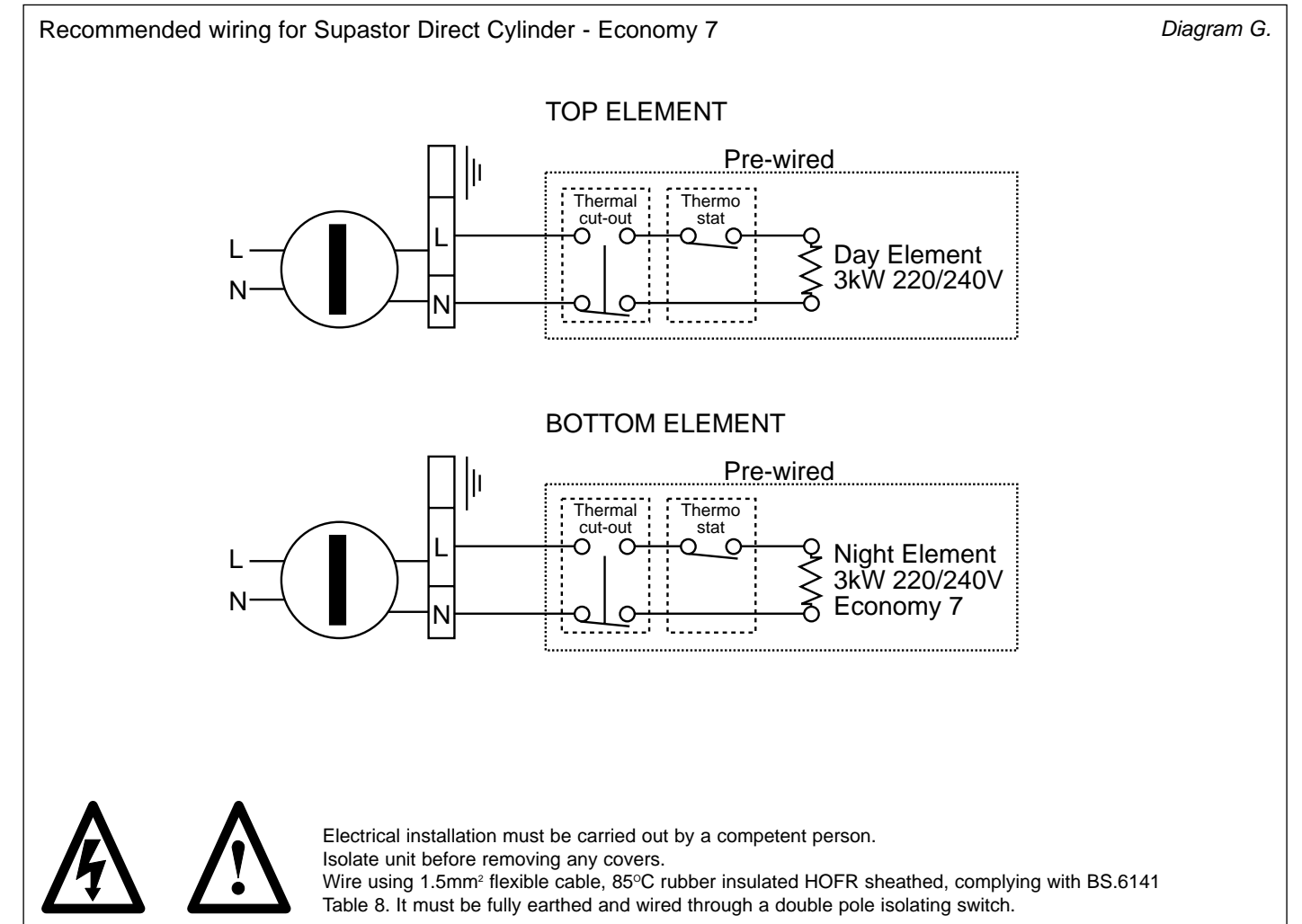
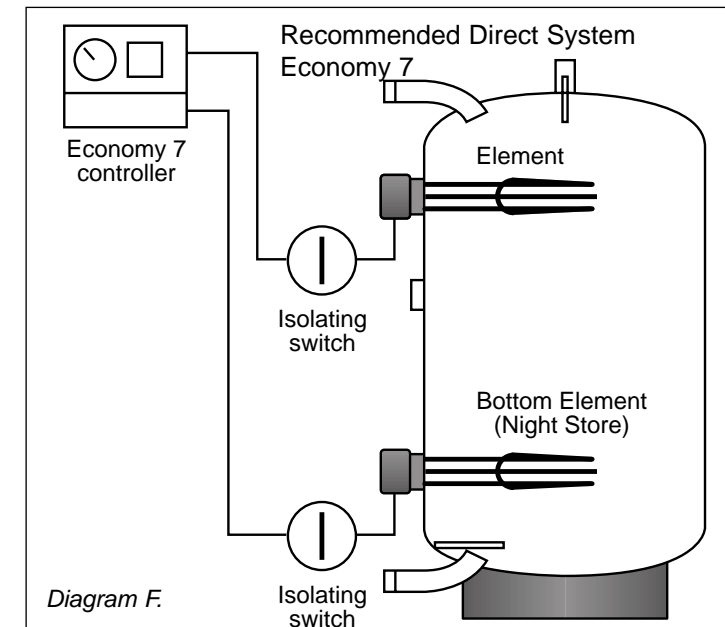

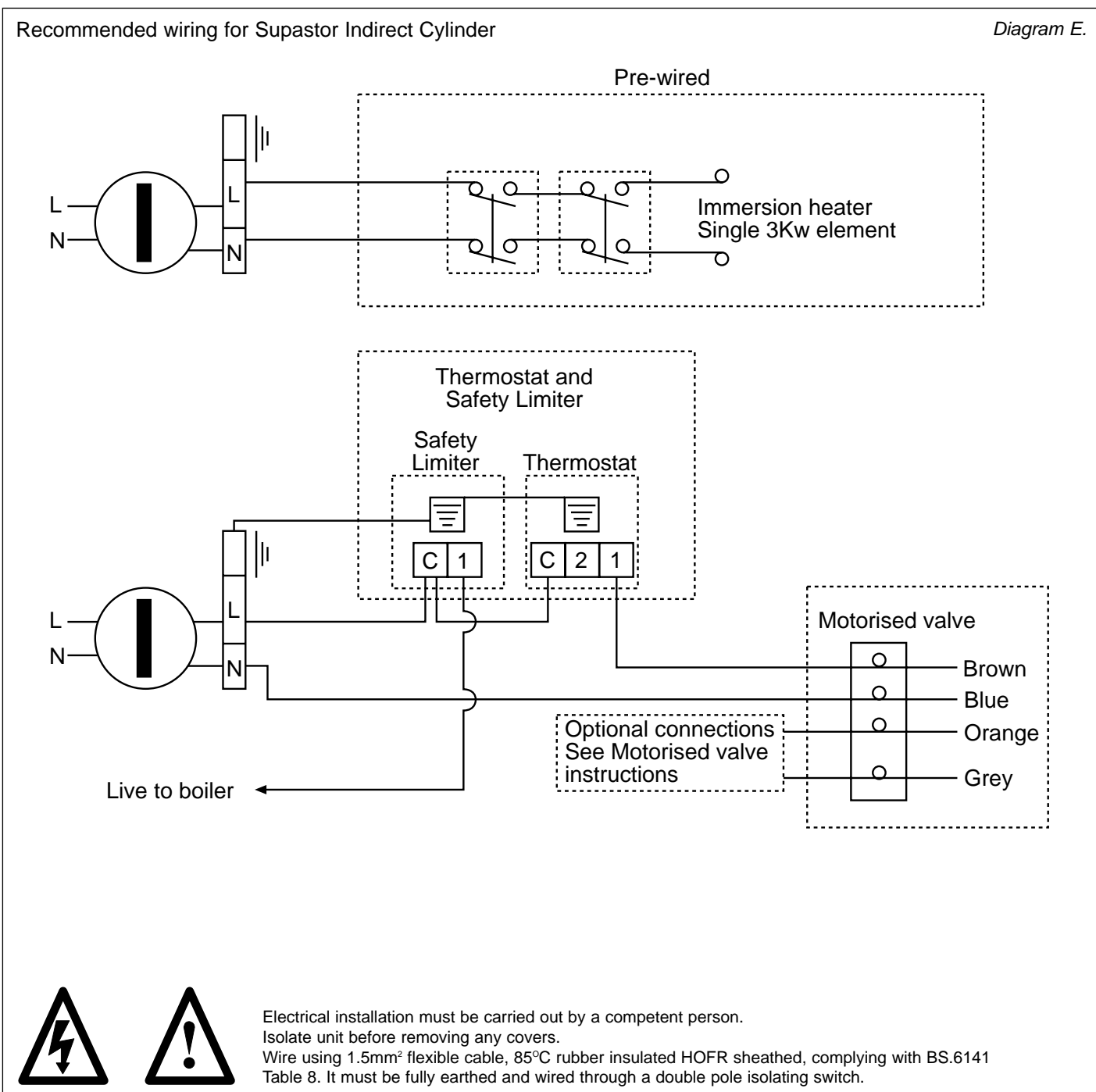
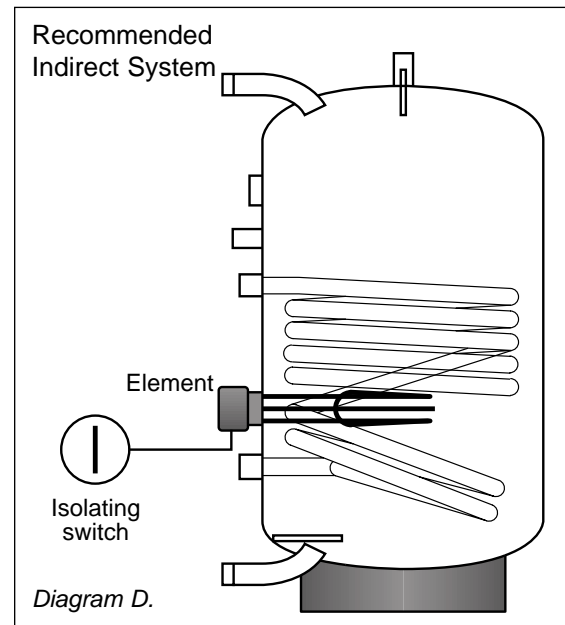
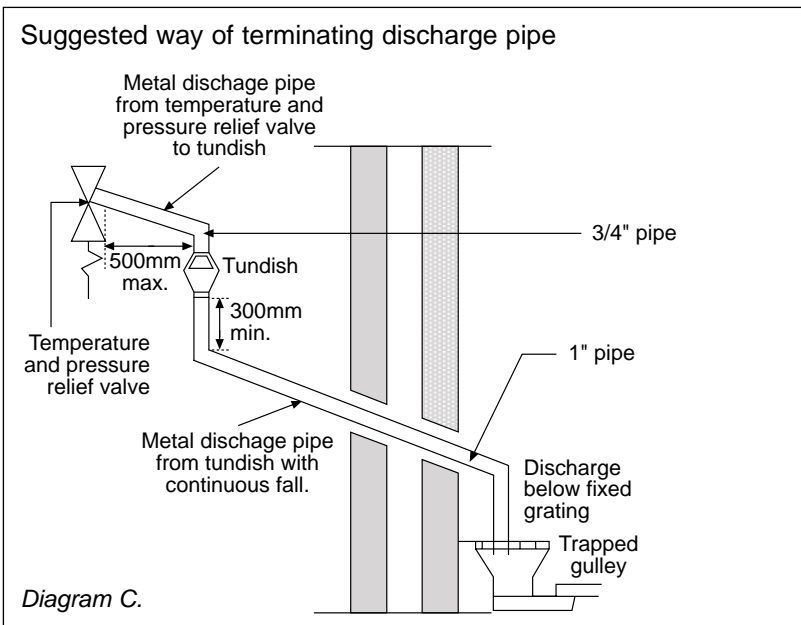

Check the controls:

1. Check and clean the strainer before refilling the system.
2. Check the pressure in the expansion vessel and top up as necessary.
3. Check the temperature and pressure relief valve manually by turning the top cap.
4. Check the expansion relief valve manually by turning the top cap.
5. Check discharge pipes for both the temperature and pressure relief valve and the expansion relief valve for obstructions.

SUPASTOR ANODE OPTION

An option is available to replace the magnesium anode with a Flamco impressed current anode. The installation should be carried out as follows: Remove the magnesium anode from the Supastor cylinder, using a 1.1/4" x 3/4" bush insert the Flamco impressed current anode.

Important:

The Flamco impressed current anode must be earth bonded to the cylinder.

To ensure the correct functioning of the Flamco 'ICA' the following information relating to safety must be strictly observed.

1. To avoid annoying gas accumulation within the cylinder, it is essential that the storage water must be drawn from the cylinder once a month.
2. Never unplug the 'ICA' when the cylinder is storing water as this will disable the anode protection.
3. The potentiostat is housed in a protective casing and is pre-wired for ease of installation.
4. Only use the original connection leads.
5. Do not under any circumstance alter the length of the connection leads.
6. Site the potentiostat adjacent to the Supastor unvented cylinder.
7. take a 220/240V supply to the Flamco 'ICA' potentiostat.

The Flamco 'ICA' connecting cables are identified as follows:

- Black cable = Earth.
- Black and white cable = Flamco 'ICA' connection.

FAULT FINDING

FAULT	POSSIBLE CAUSES	REMEDY
No hot water flow.	1. Mains cold water supply shut-off.	Check and open isolating and/or stop valve. If no water flow check with local water authority.
	2. Line strainer blocked.	Turn off mains water supply, remove and clean line strainer.
	3. Cold water safety group fitted incorrectly.	Check direction of flow arrows on the valve. Refit in the correct position if necessary.
Reduced flow rate.	1. Low mains water pressure.	Check pressure, xonsult local water authority if necessary.
	2. Strainer partially blocked.	Turn off mains water supply, remove and clean strainer.
	3. Size of service pipe too small.	Pipe size should be increased.
Water from hot taps is cold.	1. Direct immersion heater is not switched on.	Check immersion heater, switch on if necessary.
	2. Direct thermal cut-out has operated.	Test thermostat operation and wiring, if faulty correct or replace. Re-set cut-out.
	3. Boiler programmer set to central heating only. (Indirect model).	Check switch on domestic hot water if necessary.
	4. Boiler is not functioning. (Indirect model).	Check boiler operation, if fault suspected consult manufacturer's instructions.
	5. Indirect thermal cut-out has operated.	Test thermostat operation and wiring, if faulty correct /replace. Re-set cut-out.
	6. Motorised valve jammed or not wired correctly. (Indirect model).	Check wiring and operation of motorised valve, if faulty correct/replace as necessary.
Discharge from pressure and temperature relief valve.	1. Pressure above 7 bar, failure of pressure reducing valve. Temperature above 90°C, failure of thermal control.	Shut down boiler or immersion heater. Check pressure reducing valve and thermal controls. Replace if necessary.
Discharge from expansion relief valve.	1. Pressure reducing valve faulty.	Check pressure from valve. Replace if over 3.5 bar.
	2. When heater is heating, faulty expansion vessel or lost charge.	Check charge in vessel. Re-charge vessel to 3.5 bar or replace if necessary.

GUARANTEE

Flamco UK Limited guarantee that should this water heater prove to be defective by reason of faulty manufacture during the periods stated below, will replace the defective parts or product free of charge on the condition that:-

- The appliance has been correctly installed by a competent installer and used only on the supply voltage stamped on the rating plate.
- The appliance has been used and maintained in accordance with these instructions and has not been tampered with or otherwise subjected to misuse, neglect or accident.
- The appliance has not been taken apart, modified or repaired except by a qualified service engineer.
- Evidence of the date of purchase, in the form of an invoice, receipt or hire purchase documents, must be included with the appliance when returned under guarantee.

The guarantee will be applicable from the date of purchase or commencement of hire purchase for the following periods:-

- 12 months on electrical parts and components.
- 3 years on the cylinder tank.



Flamco UK Limited