

Installation and Servicing Instructions

Alpha GasSaver GS-1

**Passive Flue Gas Heat Recovery Device (PFGHRD)
for use with an Alpha CD Condensing Boiler**

IMPORTANT: Read these instructions BEFORE installing the boiler

For Technical help or for Service call ...
ALPHA HELPLINE Tel: 0844 8718764
website: www.alpha-innovation.co.uk

Alpha
HEATING INNOVATION

Nepicar House, London Road,
Wrotham Heath, Sevenoaks,
Kent TN15 7RS



Recognised by the Governments
standard assessment procedure (SAP)
EEC Accredited



Patent Protected No. 2420174
Other Patents Pending

Leave these instructions with the User

CONTENTS

1	Introduction	2	6	Commissioning	7
2	Technical data	2	7	Routine inspection	7
3	How does GasSaver work	3	8	Short parts list	8
4	General installation information	4	9	Inspection history	8
5	Installation	5			

1 INTRODUCTION

The Alpha GasSaver is an energy saving device listed in the Government's SAP Appendix Q as a passive flue gas heat recovery device (PFGHRD) and is fitted to the flue adaptor on top of an Alpha CD condensing boiler. A wall bracket is provided to support the GasSaver device in the correct position above the boiler. Also supplied are a blending valve, template and an outer flue clamp.

The GasSaver device recycles heat recovered from the flue exhaust gases which is used to pre-heat the incoming cold mains water supply before entering the gas fired combination boiler or unvented storage cylinder, thereby reducing gas consumption and improving domestic hot water efficiency. The GasSaver is maintenance free, requires no controls and easy to install.

IMPORTANT

The Alpha GasSaver must be installed as detailed in these instructions and the boiler and flue must be installed in accordance with the instructions supplied with the boiler. Failure to do so will negate the warranty supplied with this unit.

It is the law that all gas appliances are installed by a competent person, ie Gas Safe registered personnel, in accordance with the following recommendations:-

Current Gas Safety (Installation and Use) Regulations

All current Building Regulations issued by the Department of the Environment, i.e. Approved Document L1

Building Standards (Scotland) (Consolidation) Regulations issued by the Scottish Development Department

UK Water Regulations/Byelaws (Scotland)

Health & Safety Document No. 635

The installation should also be in accordance with the following British Standard Codes of Practice:-

BS 5440:1	Flues
BS 5449	Forced circulation hot water systems
BS 5546	Installation of hot water supplies for domestic purposes
BS 6700	Design, installation, testing and maintenance of services supplying water
BS 6798	Installation of gas fired hot water boilers
BS 6891	Gas installation
BS 7593	Code of Practice for treatment of water in heating systems
BS 7671	Requirements for electrical installations, IEE Wiring Regulations

Failure to install this unit or the boiler correctly could lead to prosecution. It is in your own interest and that of safety to ensure that you comply with the law. Manufacturer's instructions must **NOT** be taken in anyway as over-riding statutory obligations.

Note: Alpha CD condensing flue components **must** be used when the GasSaver is used with an Alpha CD boiler.

2 TECHNICAL DATA

2.1 DHW SYSTEM

Maximum Inlet Water Pressure	*5 bar
Minimum Inlet Water Pressure	0.2 bar
Maximum Water Flow Rate	18 l/min
Minimum Water Flow Rate	2.5 l/min
Inlet Water Pipe Connection	½" BSP to 15 mm
Outlet Water Pipe Connection	½" BSP to 15 mm
Heat Exchanger Coil Water Content	2.7 litre

2.2 COMPONENTS

DHW Heat Exchanger	Stainless Steel
Condensate Store & Flue Connection	Stainless Steel
Outer Casing	Steel - White Paint
Blending Valve Setting at Boiler Inlet	30°C
Blending Valve Connections	15 mm

* If inlet water pressure is above 5 bar a pressure reducing valve (PRV) must be fitted.

2.3 GENERAL

Case Dimensions	Height	278 mm
	Width	400 mm
	Depth	285 mm
Lift Weight (empty)		15.6 kg
Lift Weight (full)		24 kg
Condensate Store Capacity		5.75 litre
Flue Connections		60/100 Concentric
Inner Flue Duct		60 mm
Outer Air Duct		100 mm

2.4 INSTALLATION

Min. Clearances required from casing of GasSaver	Top	215 mm
	Bottom	75 mm from boiler
	Sides	20 mm
	Front	450 mm
Hole size required for flue assembly		110 mm dia.
Equivalent flue length of GasSaver		2 m of flue length

2.5 PRESSURE LOSS

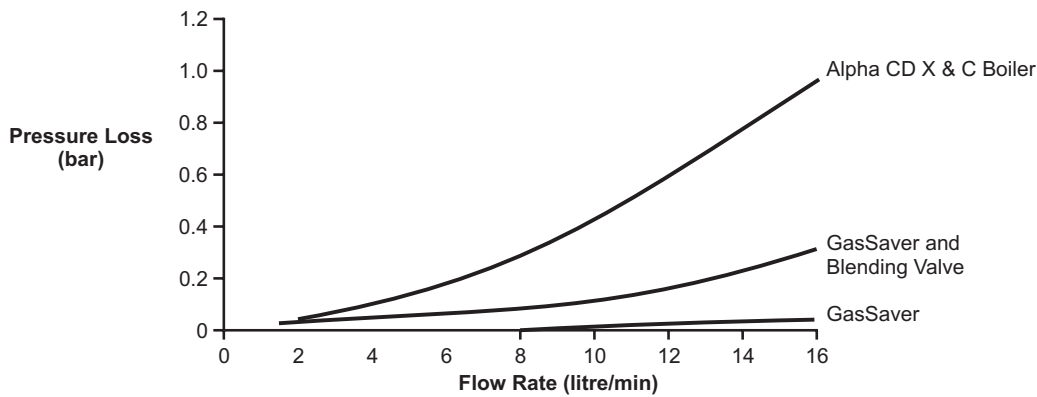

3 HOW DOES GASSAVER WORK

The GasSaver is a boiler flue gas heat recovery device. The heat is recovered by using a gas to water heat exchanger to extract heat from the hot flue gases that are usually exhausted into the atmosphere and the heat within them wasted. This reclaimed heat is then used to pre-heat the cold water supply to the boiler, thereby reducing the energy required (using less gas) to heat the water to the set hot water outlet temperature.

During the process of extracting the heat from the flue gases further condensing of the moisture within the flue gas occurs, this condensate is used to form a thermal store within the GasSaver, allowing more recovered heat to be stored and used for recycling thereby using less gas.

The flue gases leaving the GasSaver are dryer and at a much lower temperature than normal boiler flue gases thereby reducing plumbing and the problems associated with plumbing.

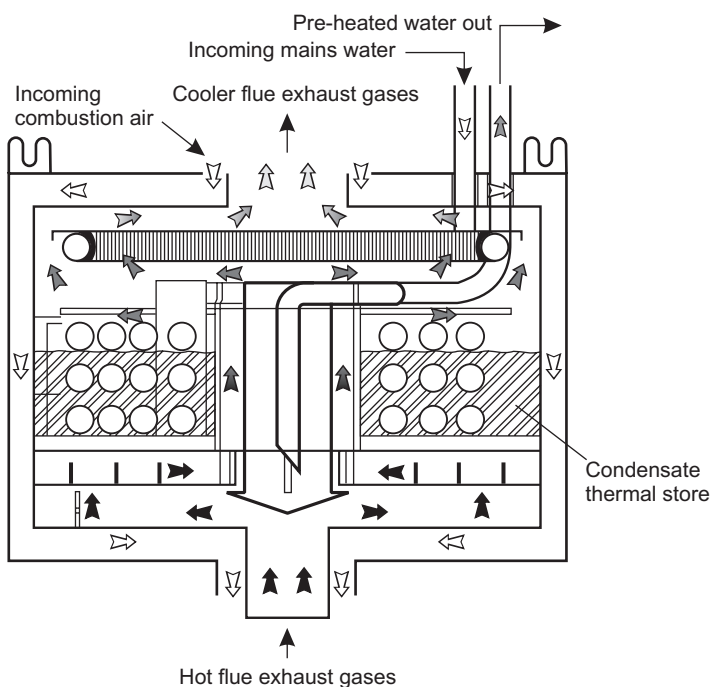

Fig. 1

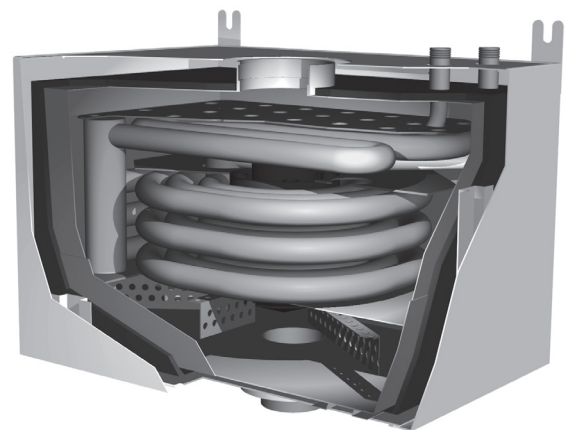

Fig. 2

4 GENERAL INFORMATION

4.1 TYPES OF INSTALLATION - Fig. 3 and 4

Depending on the type of boiler used, the GasSaver should be installed as shown in one of the following schematics Figs. 3 and 4.

IMPORTANT: Only use connection fittings approved for use with stainless steel pipework when connecting to the GasSaver inlet and outlet pipework.

Combination Boiler only

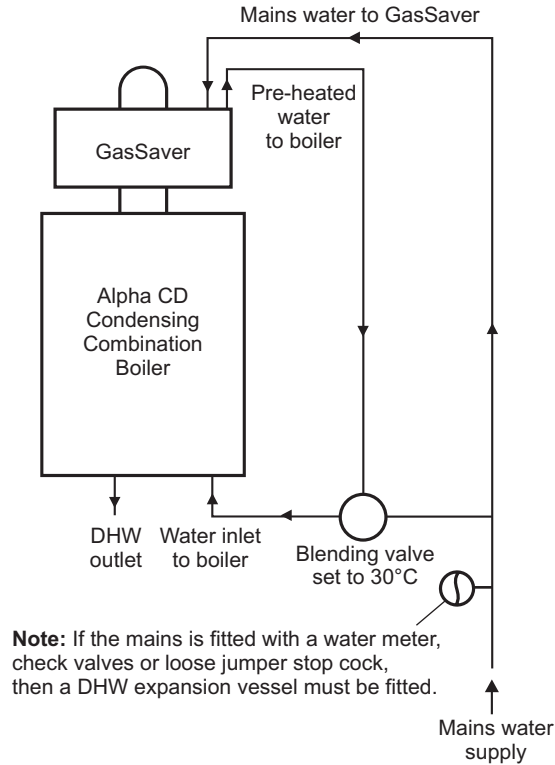

Fig. 3

System or Regular Boiler with Unvented Store

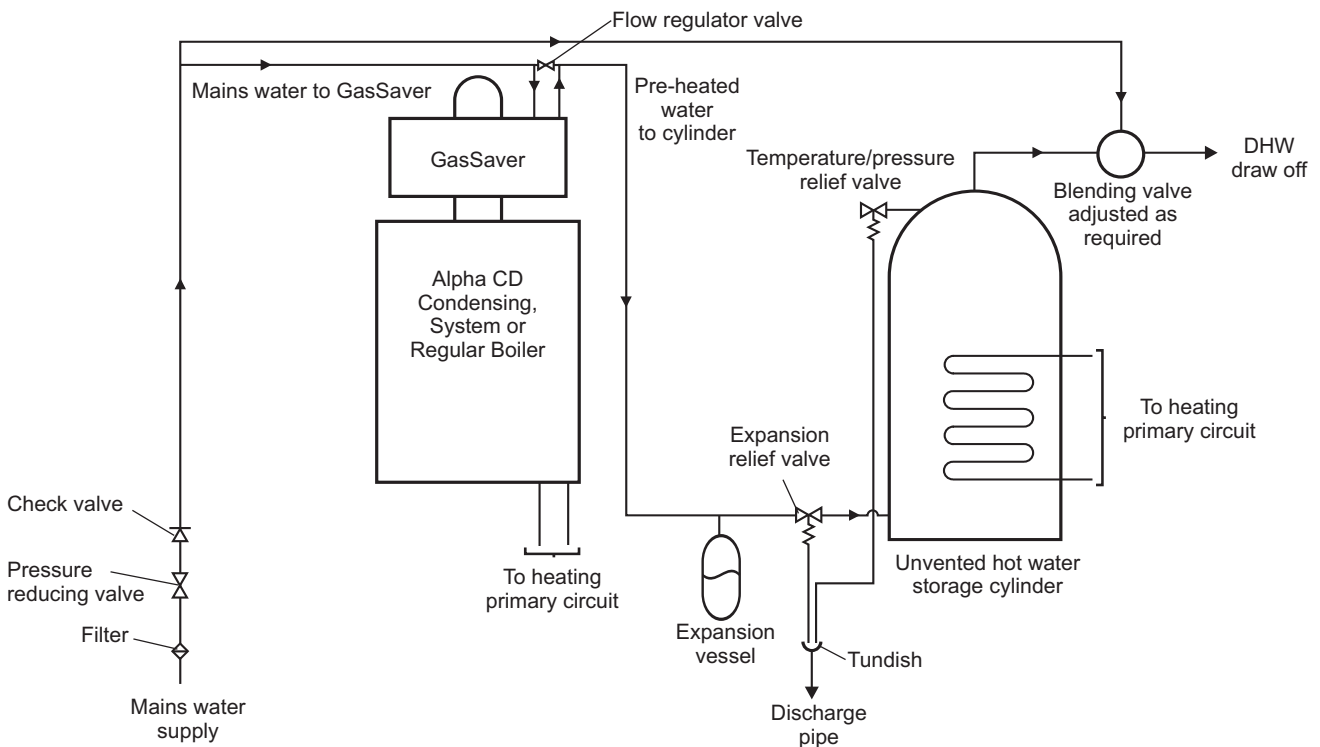

Fig. 4

4.2 DOMESTIC HOT WATER SYSTEM

The minimum flow rate needed for the boiler flow switch and burner to operate is 2.5 litres/min.

The incoming mains water pressure should be between 0.2 and 5 bar to ensure efficient operation. If the pressure is above 5 bar a pressure reducing valve must be fitted.

To ensure economic use, the pipe runs between the boiler and taps should be in 15 mm copper pipe and be as short as possible. Where possible the pipework should be insulated to reduce heat loss.

All taps and mixing valves used with the hot water system must be suitable for operating at a mains pressure of up to 8 bar.

Showers - A shower may be used with the boiler if required.

If a loose or flexible head type shower is used it may require the fitting of a double check valve, to comply with Water Bye Law 17.

Bidets - No anti-siphonage arrangements are necessary, provided the outlets are shrouded and it is not possible to attach a temporary hand held spray. A supply of direct mains fed hot and cold water is permitted provided the appliance is of the over-rim flushing type.

Before the mains water supply pipe is connected to the boiler, it should be thoroughly flushed out to avoid the danger of dirt or foreign matter entering the boiler.

5 INSTALLATION

5.1 UNPACKING - Fig. 5

- Box contents GasSaver
Mounting bracket with two top fixing bolts plus screws and wall plugs
40 mm flue clamp
Blending valve
Literature pack and wall template

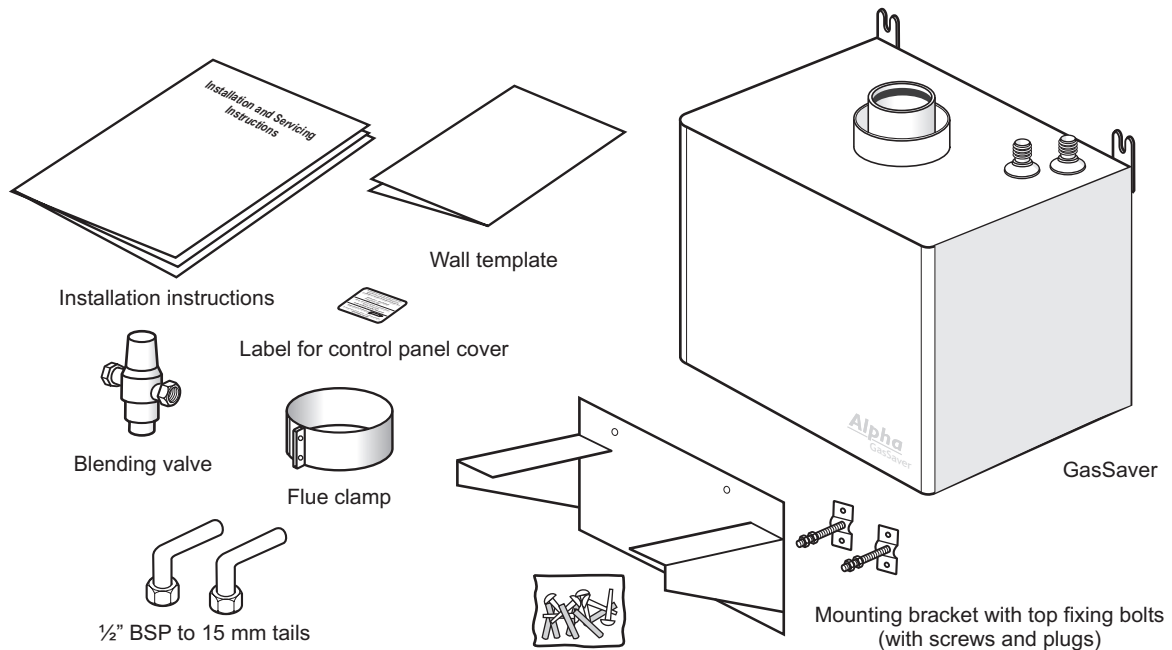

Fig. 5

5.2 MINIMUM CLEARANCES REQUIRED - Fig. 6

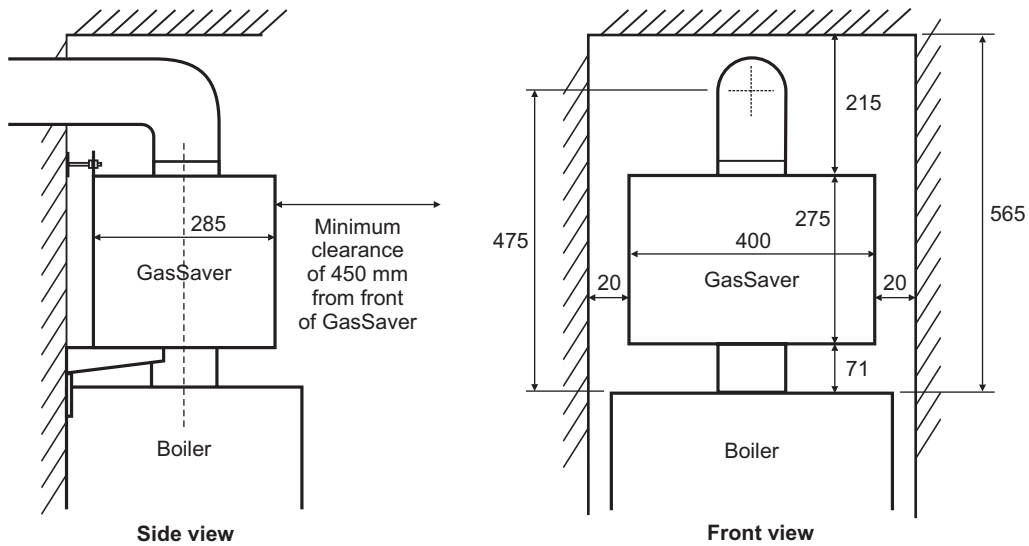

Fig. 6

5.3 FIT THE GASSAVER - Figs. 7 and 8

1. The GasSaver is positioned on top of the boiler using a wall fixing bracket and is connected directly to the boiler flue outlet. The boiler flue kit is then connected to the flue spigot on top of the GasSaver.
2. Before commencing installation, it is important to ensure that there is adequate clearance above the boiler to accommodate both the GasSaver and flue kit. Refer to Fig. 6.
3. Use the GasSaver wall template in conjunction with the boiler wall template (Fig. 7) to determine the positions of the flue hole and the holes for the various fixings.

Side exit flue - Continue the horizontal centre line of the flue across the wall to the side wall, then along the side wall by the distance of the boiler flue position from the wall the boiler is mounted on (ensure the lines are horizontal). This will give the position of the centre of the hole for the flue.

4. Drill and plug all the necessary fixing holes and cut the flue hole.
5. Mount the boiler on the wall as described in the boiler installation instructions (do not fit the flue or make the water connections).
6. Carefully pour about ½ litre of clean, cold water into the central flue spigot of the boiler. Care should be taken to ensure that no water is allowed to spill or enter the outer air duct of the flue spigot.

Note: Temporarily cover the boiler flue spigot to prevent anything from falling into it.

7. Place the GasSaver mounting bracket in position and secure with three fixing screws. Secure the top fixing bolts in position using four fixing screws.
8. Remove the temporary cover from the boiler flue adaptor. Loosely fit the flue clamp, supplied with the GasSaver and position it over the flue adaptor. Carefully lift the GasSaver into position over the boiler flue adaptor and lower it into place, keeping the unit level to ensure the GasSaver bottom flue spigot enters the boiler flue adaptor squarely.

Note: Take care not to dislodge or damage the flue seal in the boiler adaptor.

Position the GasSaver on its mounting bracket, holding it level (ensure the weight is not transferred to the boiler). Locate the top fixing bolts into the top of the GasSaver as shown in Fig. 8 and adjust the nuts to level the GasSaver.

9. When the GasSaver is level tighten the locknuts and tighten the flue clamp to seal the joint.

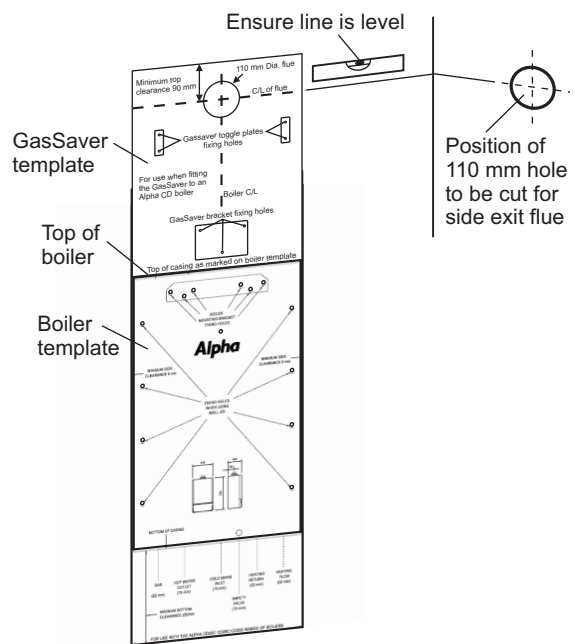

Fig. 7

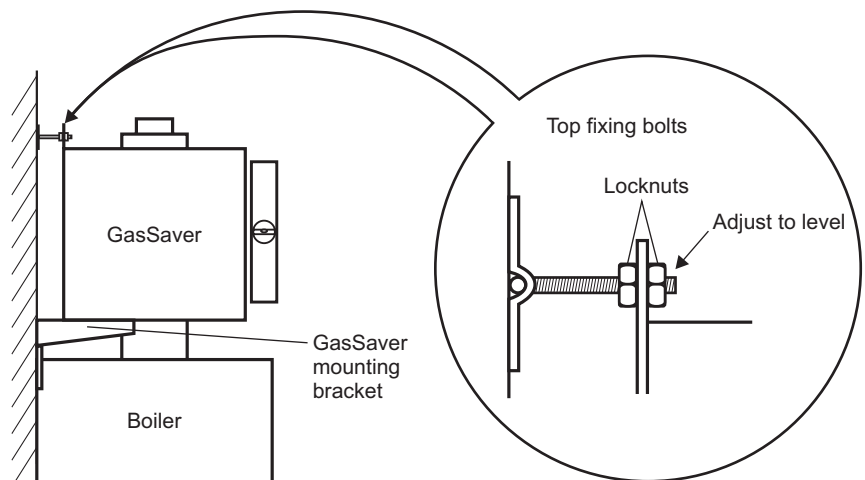

Fig. 8

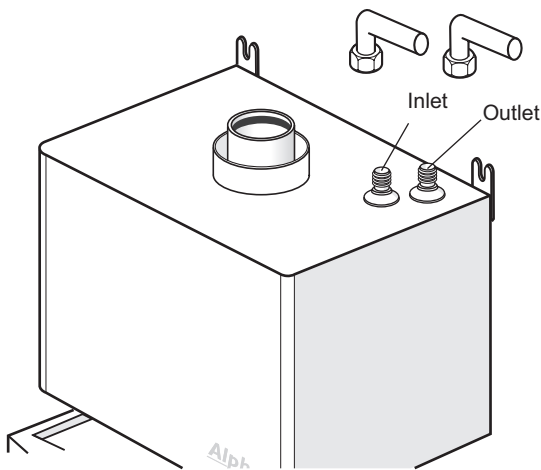

Fig. 9

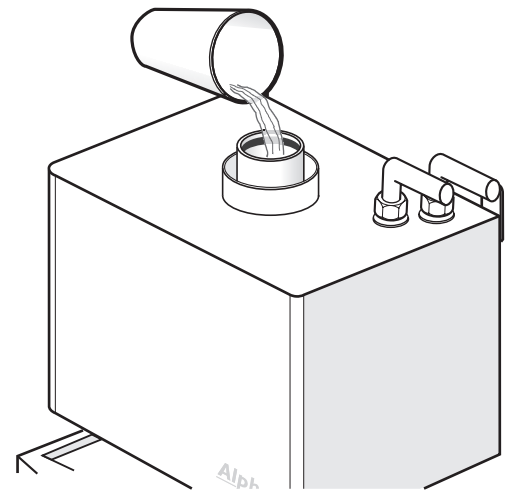

Fig. 10

5.4 CONNECT THE PIPEWORK - Figs. 3, 4 and 9

1. Fit the ½" BSP to 15 mm tails (supplied) to the inlet and outlet connections setting them in the required positions. Using either solder or compression fittings connect the cold mains inlet to the inlet pipe (marked inlet, see Fig. 9). Route the pipework from the outlet to the hot connection of the blending valve supplied with the GasSaver.
2. Connect another cold mains pipe to the cold connection of the blending valve and then connect a pipe from the mixed connection of the blending valve to the cold water inlet connection of the boiler. The blending valve is pre-adjusted to 30°C and has a locking cap to prevent incorrect adjustment. Connect any remaining system pipework as described in the boiler installation instructions.

5.5 PRIME THE GASSAVER - Fig. 10

The GasSaver relies on a store of water/condensate to deliver maximum benefit, and must be primed prior to first use.

When the installation of the pipework is completed, fill the GasSaver by carefully pouring 6 litres of clean, cold water into the top central flue spigot of the GasSaver. Care should be taken to ensure that no water is allowed to spill or enter the outer air duct of the GasSaver.

Note: It is normal for some water to run into the boiler heat exchanger and out the condensate drain whilst filling.

5.6 FIT THE FLUE

When priming is completed, attach the boiler flue kit to the top spigot of the GasSaver as described in the boiler installation instructions.

Note: The GasSaver is equivalent to a 2 m length of flue.

5.7 COMPLETE THE INSTALLATION

A self adhesive label is supplied in the GasSaver box. This label **must** be located as shown in Fig. 11 on the boiler control panel cover so that it can be easily seen when the cover is open.

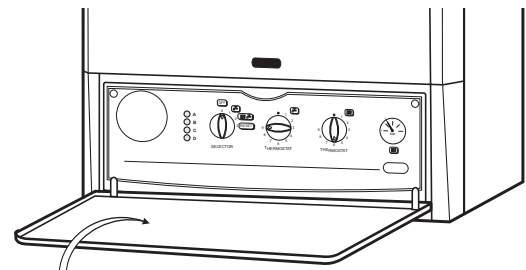

THIS BOILER IS FITTED WITH A 'PASSIVE FLUE GAS HEAT RECOVERY DEVICE' (PFGRD) RECOGNISED BY THE GOVERNMENT'S STANDARD ASSESSMENT PROCEDURE (SAP)

PFGRD brand: **Zenex GasSaver**
 PFGRD model: **GS-1**

Part No. GS-1-ALPCD (For Alpha CD Condensing Boilers)
 Serial No. GS-ALPCD-223
 ALPHA TECHNICAL HELPLINE - 0870 300 1964

ZENEX COOLFLUE TECHNOLOGY **COOLFLUE**

UK PATENT PROTECTED No. 2420174 - OTHER PATENTS PENDING
 DO NOT REMOVE THIS LABEL

Stick label supplied with GasSaver onto back of the control panel cover

Fig. 11

6 COMMISSIONING

Commission the boiler as described in the boiler installation instructions.

Turn on the cold mains supply and open all hot taps to purge any air. Close the taps and check for leaks.

7 ROUTINE INSPECTION

It is recommended that the GasSaver should be subjected to a general condition inspection at each boiler maintenance interval. Due to the simplicity of the design of the GasSaver, no maintenance is required. The unit contains no mechanical, electrical or serviceable parts.

8 SHORT PARTS LIST

Item	Part No.
Wall mounting top fixing brackets	3.021289
Wall mounting bracket kit	2.014305
Wall template	1.025992
Flue clamp (100 x 45)	6.2002120
Blending valve	1.030009
Expansion vessel (optional extra)	6.5624241
Installation and servicing instructions	1.030008
SAP label for boiler controls cover	1.030006
Alpha/GasSaver badge	1.030256

9 INSPECTION RECORD

It is recommended that the GasSaver is inspected regularly and that you complete the appropriate Inspection Record below.

Service Provider: Before completing the appropriate Inspection Record below, please ensure you have carried out the boiler service as described in the boiler instruction manual.

INSPECTION 1: Date

Engineers Name

Company Name

Telephone No.

Gas Safe card serial No.

Comments

.....

Engineers Signature

INSPECTION 3: Date

Engineers Name

Company Name

Telephone No.

Gas Safe card serial No.

Comments

.....

Engineers Signature

INSPECTION 5: Date

Engineers Name

Company Name

Telephone No.

Gas Safe card serial No.

Comments

.....

Engineers Signature

INSPECTION 7: Date

Engineers Name

Company Name

Telephone No.

Gas Safe card serial No.

Comments

.....

Engineers Signature

INSPECTION 2: Date

Engineers Name

Company Name

Telephone No.

Gas Safe card serial No.

Comments

.....

Engineers Signature

INSPECTION 4: Date

Engineers Name

Company Name

Telephone No.

Gas Safe card serial No.

Comments

.....

Engineers Signature

INSPECTION 6: Date

Engineers Name

Company Name

Telephone No.

Gas Safe card serial No.

Comments

.....

Engineers Signature

INSPECTION 8: Date

Engineers Name

Company Name

Telephone No.

Gas Safe card serial No.

Comments

.....

Engineers Signature

Alpha
HEATING INNOVATION

Alpha Therm Limited.
Nepicar House, London Road, Wrotham Heath,
Sevenoaks, Kent TN15 7RS
Tel: 0844 8718764
email: info@alpha-innovation.co.uk
website: www.alpha-innovation.co.uk

*These instructions have been carefully prepared but we reserve the right to alter the specification at any time in the interest of product improvement.
© Alpha Therm Limited 2010.*

Part No. 6.2002140